



## **4. Optical Properties of Materials**

Classification of optical materials - Optical processes in semiconductors: optical absorption and emission, charge injection and recombination, optical absorption, loss and gain. Optical processes in quantum wells - Optoelectronic devices: light detectors and solar cells - light emitting diode – laser diode - optical processes in organic semiconductor devices - excitonic state - Electro-optics and nonlinear optics: Modulators and switching devices.

### **4.1. Introduction**

The optical properties of materials are determined by the type of interaction between the electromagnetic radiation and the electrons of the atoms in the material.

We see many of the common optical characteristics of materials such as their colour, brightness, transparency, reflectivity, etc.,

Besides, these common properties, there are many more special optical properties of materials which make them useful in a wide range of optical devices.

Some of the commonly used optical materials and devices are window glasses, lenses, mirrors. Antireflection coating, etc.,

Some of the most recently developed high-technology optical devices are lasers, optical fibers, photodiodes, optical memories (CD-ROM), electro-optic modulators.

### **Definition**

The materials which are sensitivity to light are known as optical materials. These optical materials exhibit a variety of optical properties.

### **4.2. Classification of optical materials**

Generally, optical materials are classified into three types based on the nature of propagation of light namely,

(i) Transparent (ii) Translucent (iii) Opaque

#### **Transparent**

Transparent materials are the materials which transmit the light with little absorption and reflection. These materials are transparent in nature and hence, one can clearly view the object through the material.

Electrical insulated materials are transparent. Similarly, few semiconducting materials are also transparent.

#### **Translucent**

The incident light gets scattered within the materials and hence, the diffusion light is transmitted with the other side of the materials.

One cannot clearly view the object while viewing through the materials. These materials are known as translucent material.

**Opaque**

The material which absorbs the visible light is termed as opaque. When an electromagnetic radiation in the entire visible spectrum is incident on this material, either it gets reflected or absorbed.

Thus, the materials are opaque. Few semiconducting materials also exhibit this opaque nature.

**4.4 Optical processes in semiconductors**

When light incident on a semiconductor, an electron in the valence band goes to the conduction band. This process generates electron hole pairs. It is also possible for the electron and a hole to recombine and emit light.

The interaction between light and electrons in the semiconductor provides a variety of phenomena. These are used in the field of opto electronics.

The important optoelectronic interaction in semiconductors is the band-to-band transition. In the photon absorption process, a photon scatters an electron in the valence band.

Thus electron jumps to the conduction band and leaving a hole in valence band. In the reverse process the electron in the conduction band recombines with a hole in the valence band to generate a photon.

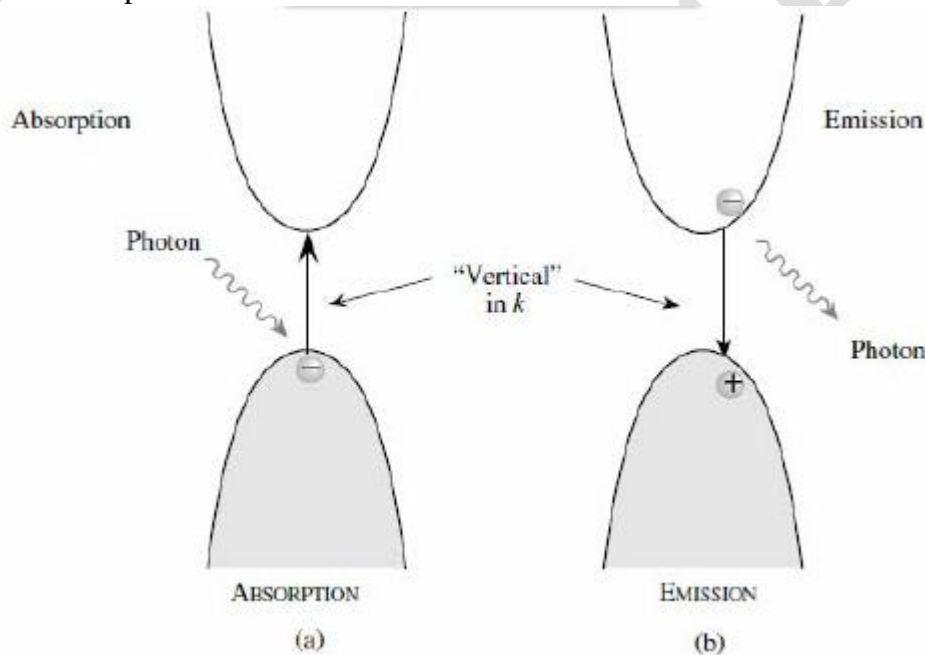

These two processes are importance for light-detection and light-emission devices. The rate of the light emission and absorption processes are determined by quantum mechanics.

**4.5. Absorption and emission of light in semiconductors**

In semiconductors, light photons is absorbed in several ways. In intrinsic semiconductors such as Si, Ge and GaAs, light photons is absorbed to create electron-hole pairs. This absorption causes electrons to jump across the energy band gap from the valence band to the conduction band as shown in figure.

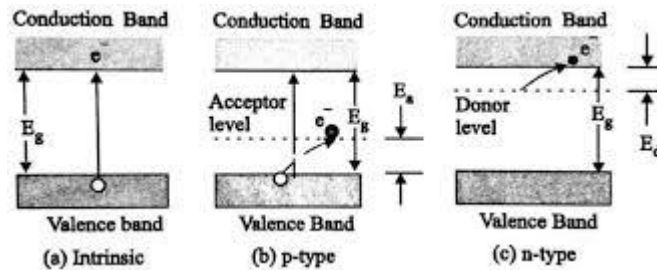

This transition occurs i.e., the excitation of electrons due to absorption can take place if the photon energy is greater than that of the band gap  $E_g$  that is if  $h\nu > E_g$

Where  $h$  – Planck's constant;  $\nu$  – frequency of light photon,

In terms of wavelength  $\frac{h\nu}{\lambda} > E_g$

The maximum wavelength for visible light  $\lambda_{max}$  is about  $0.7 \mu\text{m}$ . Therefore, the minimum band gap energy  $E_{g(\text{min})}$  for which there is absorption of visible light is given by

$$E_{g(\text{min})} = \frac{hc}{\lambda_{max}}$$

By substituting  $h = 6.626 \times 10^{-34} \text{ Js}$ ,  $C = 3 \times 10^8 \text{ ms}^{-2}$  and  $\lambda_{max} = 0.7 \times 10^{-6} \text{ m}$

$$E_{g(\text{min})} = 2.84 \times 10^{-19} \text{ J (or) } 1.8 \text{ eV}$$

The result indicates that all visible light is absorbed by those semiconductors having band gap energies less than about  $1.8\text{eV}$ . Thus, *these semiconductors are opaque*.

In extrinsic semiconductors, the presence of acceptor and donor impurities creates new energy levels namely acceptor level ( $E_a$ ) (p-type semiconductor) and donor level ( $E_d$ ) (n-type semiconductor) as shown in figure. These impurity levels lie within the band gap of the material. Light radiation of specific wavelength may be absorbed as a result of electron transitions from or to those impurity levels within the band gap.

#### 4.6. Charge injection and radiative recombination

Electrons and holes can be injected into the conduction and valence band in a number way. The light incident on the material and the absorption of photons creates electron-hole pairs.

We also use an external battery bias in a p-n diode also inject electrons and holes.

The electrons and holes will recombine with each other and the electron in the conduction band will return to the valence band.

This recombination process can be made in two processes. They are (i) radiative processes and (ii) non-radiative processes.

In the radiative process the e-h pair recombines and a photon is emitted. This is the inverse of the photon absorption process.

Electron-hole pairs can also recombine without emitting light. Instead, they may emit (i) heat or (ii) a photon or (iii) a long-wavelength photon together with a photon. Such processes are non-radiative processes.

As the electrons and holes are pumped into the semiconductor they recombine through the process of spontaneous emission. This process does not require photons to be present for the photon emission process to occur. The spontaneous recombination rate is quite important for both electronic and optoelectronic devices.

Types of carrier injections

##### (i) Minority Carrier Injections

If  $n \gg p$  and the sample is heavily doped *n-type* recombination rate is proportional to hole density. Thus, the recombination rate is proportional to the minority carrier density (holes in the case)

##### (ii) Strong injection

This case is important when a high density of both electrons and holes is injected. The rate of recombination proportional to majority charge carrier.

**(iii) Weak injection**

In this case, the rate of recombination is very low.

(iv) At low junction, the electrons have a low probability to find a hole with which to recombine.

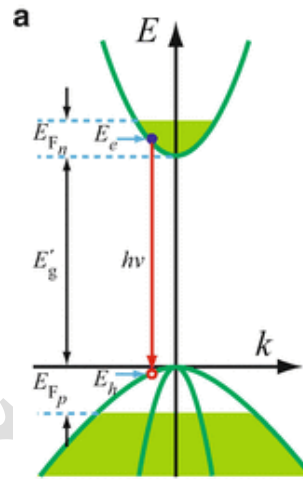

**4.7. Optical absorption loss and gain**

The photon flux associated with an electromagnetic wave travelling through a semiconductor is denoted by

$$I_{ph} = I_{ph}^0 \exp(-\alpha x) \tag{1}$$

Where  $\alpha$  is the absorption coefficient which is usually positive and  $I_{ph}^0$  is the incident light intensity at  $x = 0$ .

The optical intensity which is the photon flux multiplied by the photon energy  $h\nu$  falls as the wave travels. The electrons are pumped in the conduction band and holes in the valence band. The electron-hole recombination process (photon emission) can be stronger than electron-hole generation (photon absorption)

In general, the gain coefficient is defined by

Gain coefficient = emission coefficient – absorption coefficient

Let  $f^e(E^e)$  and  $f^h(E^h)$  are the electron and hole occupation. The emission coefficient depends upon the product of  $f^e(E^e)$  and  $f^h(E^h)$ . Similarly, the absorption coefficient depends upon the product of  $(1-f^e(E^e))$  and  $(1-f^h(E^h))$ . Here the energies  $E^e$  and  $E^h$  are related to the photon energy by the conduction of vertical  $k$  transitions.

For these transitions we have  $E^e = E_c + \frac{m_r^*}{m_e^*} (h\nu - E_g)$

$$E^h = E_v + \frac{m_r^*}{m_h^*} (h\nu - E_g) \tag{2}$$

The occupational probabilities  $f^e$  and  $f^h$  are found by the quasi-Fermi levels for electrons and holes.

The gain is the difference of the emission and absorption coefficient. It is now proportional to

$$g(h\nu) = f^e(E^e) f^h(E^h) - \{1 - f^e(E^e)\} \{1 - f^h(E^h)\} \tag{3}$$

The optical wave has a general spatial intensity dependence:

$$I_{ph} = I_{ph}^0 \exp((h\nu) x) \tag{4}$$

and if  $g(h\nu)$  is positive, the intensity grows because additional photons are added by emission. The condition for positive gain requires “inversion” of the semiconductor system Equation (3)

$$f^e(E^e) + f^h(E^h) > 1 \tag{5}$$

The quasi-Fermi levels must penetrate their respective bands for this condition to be satisfied.

**4.8. Carrier generation and recombination processes**

It is the process of generating number of hole - electron pairs per unit volume second. Basically there are three types of carrier generations.

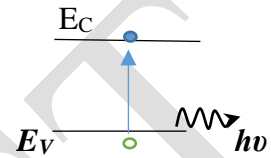

**(i) Photo generation**

When a photon is incident with energy  $h\nu$  greater than the energy of band gap of a semiconductor, then the electrons in valence band absorb this photon and jump to conduction band thereby generating electron - hole pair. For different wavelengths of light with different energies it can take an electron in higher conduction band states.

**(ii) Phonon generation**

When a semiconductor is under thermal excitation, with increase of temperature of the semiconductor, lattice vibrations increase which give rise to more phonons. Due to more lattice vibrations, covalent bonds in the semiconductor break down and electron - hole pairs are generated.

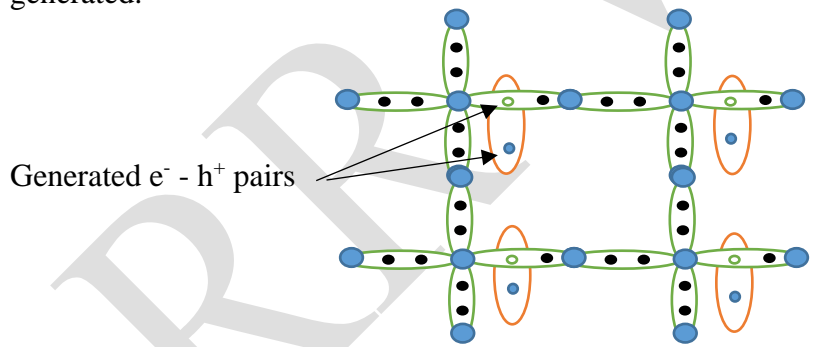

**(iii) Impact ionization**

When a semiconductor is under an electric field, one energetic charge carrier will create another charge carrier. For a very high electric field, it results in an avalanche breakdown.

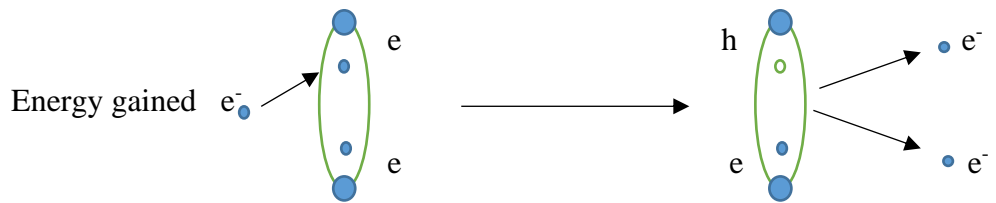

**Recombination:**

It is a process in which the electron – hole pair are annihilated during recombination per volume second. Recombination occurs in three ways:

(i) **Radiative recombination**

This process occurs in direct band gap semiconductor. When an electron in the conduction band minimum falls to valence band maximum without change in momentum. One photon of energy  $h\nu$  is emitted. This is direct recombination. Here the electrons in the highest energy states of conduction band will come back to conduction band minimum by non-radiative transition (heat).

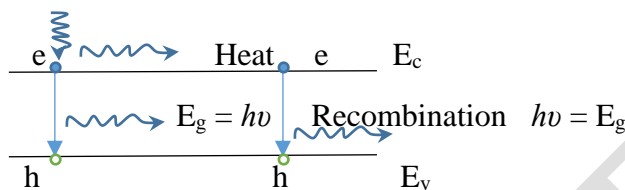

(ii) **Shockley - Read - Hall recombination**

In this process, electrons from the conduction band minimum or holes from the valence band maximum are come to a defect level intermediate between  $E_c$  and  $E_v$  by radiation energy as photons or phonons. These intermediate levels are called trapping level. Hence either the electron or the hole from the trapping level returns to the valence band or conduction band. They are not set free & hence it is said to be trapping level. Generally this process occurs in impure semiconductors.

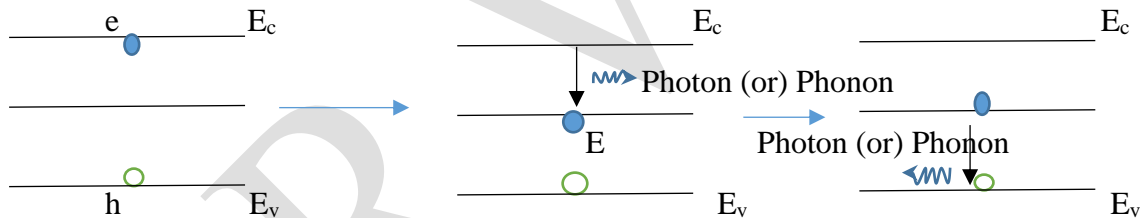

(iii) **Auger recombination**

Here three carriers are involved. i.e., the electron and hole recombine may have an energy which is given to the third free electron in the conduction band. Then the excite third electron comes back to the conduction band edge by emitting energy as heat. Generally an Auger recombination occurs for heavily doped material.

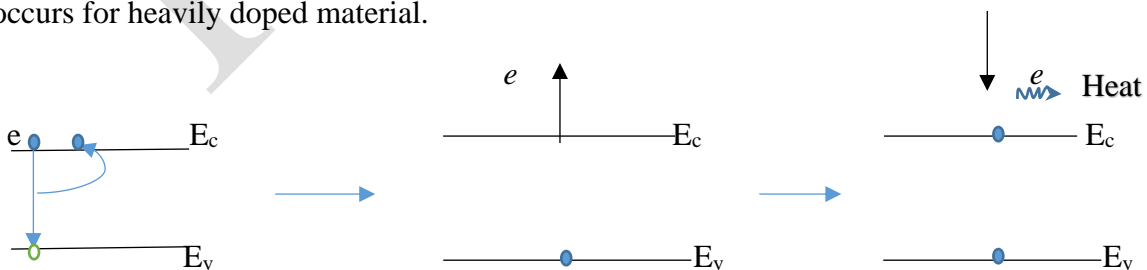

**4.9. Optical absorption, loss and gain**

The term “Well” refers to a semiconductor region that is grown to possess a lower energy, so that it acts as a trap for electrons and holes. These are called quantum wells because these semiconductor regions are only a few atomic layers thick. Quantum wells are real-world implementation of the *particle in one-dimensional box* problem.

The basic properties of a quantum well is understood from the simple *particle in a box* model. In quantum well an isolated thin semiconductor sheet of thickness  $L$  is considered as length of the box.

Solving the Schrodinger equation and applying boundary conditions result in the following quantized energies for charge carrier.

$$E_n = \frac{n^2 h^2}{8mL^2} \quad \psi_n(x) = \sqrt{\frac{2}{L}} \sin\left(\frac{n\pi x}{L}\right) \quad (1)$$

$n = 1, 2, 3, \dots$  are quantum numbers

$h$  = Planck’s constant

$m$  = mass of charge carrier

Finite quantum wells are formed by sandwiching a thin layer (<50 nm) of one semiconductor (GaAs) between two layers of another larger band gap semiconductor (GaAlAs) barriers. This finite depth potential well is shown in figure a.

The figure b. shows energies and wave functions for a finite depth well. The energy of the first allowed electron energy level in a typical 100 Å GaAs quantum well is about 40 meV calculated using equation (1)

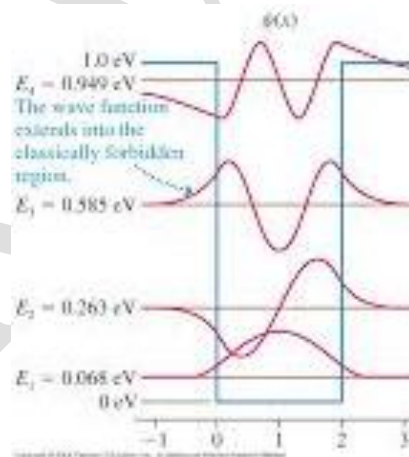

The optical transition is proportional to the density of the states at the initial point in the valence band and the final point in the conduction band.

The energy absorption spectrum therefore exhibits a very different form for nanostructures of different dimensionality.

In quantum wells for confined the direction instead of momentum conservation a selection rule applied. This rule states that only transition between states of the same quantum number in the VB and CBs are allowed.

This rule followed from the fact that the optical absorption strength is proportional to the overlap integral of the conduction and valence wave functions.

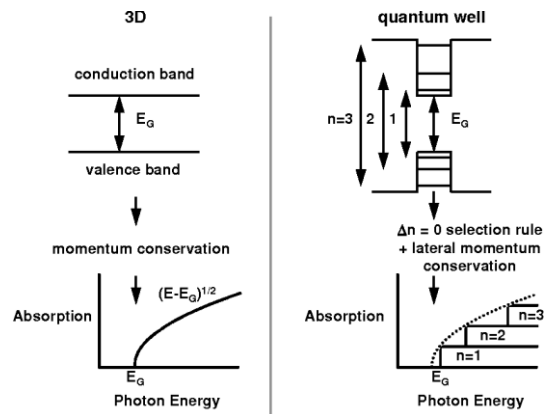

In quantum well the electrons and holes are still free to move in the directions parallel to the layers. Therefore, there is a deviation in discrete energy states for electrons and holes. There are ‘sub bands’ that start at corresponding to each of the energies calculated for the confined states.

The density of states turns out to be ‘step’ that starts at the appropriate confinement energy. Optical transitions must still conserve momentum in this direction and just as for bulk semiconductors. The optical absorptions must still therefore follow the density of states. Hence in this simple model, the optical absorption in a quantum well is a series of steps with one step for each quantum number  $n$  as shown in figure.

As a consequence of quantum confinement in quantum well, the effective band gap of a semiconductor  $E_g^{ef}$  increases from its bulk value by the addition of the electron and hole confinement energies corresponding to the states with  $n = 1$  given by

$$E_g^{ef} = E_g + \frac{h^2}{8m_e^*L^2} + \frac{h^2}{8m_h^*L^2}$$

This effective band gap will determine the energy of the emitted photons. The band gap can be altered by varying the thickness of the wall. The carrier energy is quantized for the motion normal to the well but within the well motion is unrestricted.

### 4.10. Optoelectronic devices

Optoelectronic devices play a vital role in the fiber optics communication, switching and logic gates. These are based on variation of optical parameters and subsequent electrical output. Optoelectronics combines the properties of light with the capabilities of electronics. The importance of optoelectronic applications results from the advances in semiconductor materials, optical fiber communication, optical data processing, display devices and data storage devices.

#### Light detectors

For processing the light signal at the receiver end of the fiber link we require a device to convert the light signals to electrical wave forms. This task is done by the photo-detectors.

#### Definition

It is a device which converts light signal into electrical waveforms.

#### Types:

There are three types namely: (i) Photo emissive (ii) Photo conductive (iii) Photo voltaic

#### Photo-Emissive Photo-Detector



The emission of electrons from a photo cathode by the incident photon is called photo-emission

Example: (i) Photo tubes (ii) Photo-multiplier tubes.

The size of these is normally very large and hence not suitable for use as fiber optic detectors.

### Photo-Conductive Devices

These types of devices have variation of resistance due to incident light on the photo-conductive materials.

Example

Materials like CdS

Intrinsic semiconductor materials like PIS, PhTe

Extrinsic semiconductor like doped Ge and Si

They are not suitable for use in fiber optic communication purpose since they have low frequency response.

### Photo-Voltaic Devices

Semiconductor junction photodiodes are called as photo-voltaic devices. They are almost ideal for fiber systems. We will study three forms of these devices

1. PN junction photo detector
2. PIN photo diode
3. Avalanche photo diode (APD)

PN junction photo diode as in figure explains the basic detection mechanism of a junction detector. When reverse biased, the potential energy barrier between the *p* and *n* regions increases. Free electrons (which normally reside in the *n* region) and free holes (normally in *p* region) cannot climb the barrier, so no current flows.

The junction refers to the region where the barrier exists. Because there are no free charges in the junction, it is called the depletion region. Figure shows an incident photon being absorbed in the junction after passing through the *p* layer. The absorbed energy raises a bound electron across the band gap.

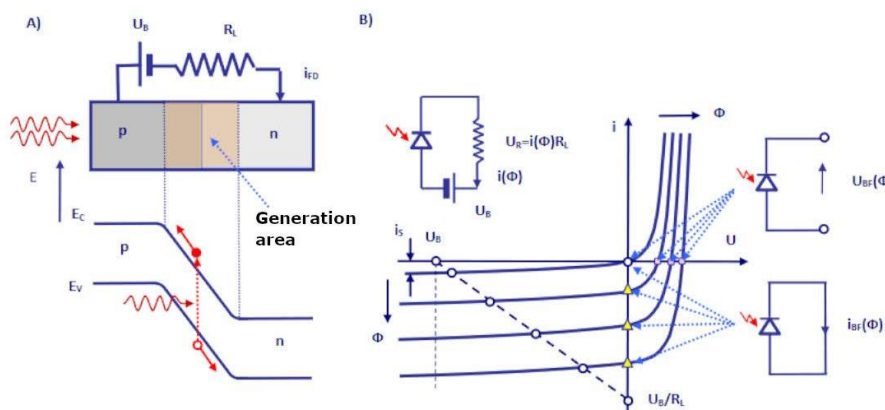

**Quantum efficiency**

The quantum efficiency  $\eta$  is defined as the number of electron-hole pairs generated by the number of incident photons.

$$\text{i.e., } \eta = \frac{\text{Number of electron-hole pairs generated}}{\text{Number of incident photons}} = \frac{i/e}{P/h\nu} = \frac{i h\nu}{eP}$$

where  $i$  – photo current developed;  $e$  – charge on electron;  $P$  – incident optical power;  $h\nu$  – energy of incident photon.

**PIN photodiode**

The frequency response can be improved in the  $pn$  junction is separated by an intrinsic region. The introduction of the intrinsic region decreases the junction capacitance. This is called Positive Intrinsic Negative (PIN) photo diode.

A PIN diode has an intrinsic semiconductor at the center and  $p$  type and  $n$  type regions at the end as shown in figure. It is reverse biased (5-20V). The reverse biasing is used to attract the charge carriers from the intrinsic regions.

When light is incident on the PIN diode, the intrinsic region receives more amount of light because of its large size. The photons incident on the intrinsic region produces electron-hole pair.

The electron is raised from the valence band to the conduction band, leaving the hole. The electrons are attracted by the reverse biasing and hence move away from the junction. The movement of electrons in the conduction band creates the flow of charge and hence the light energy gets converted into electrical energy.

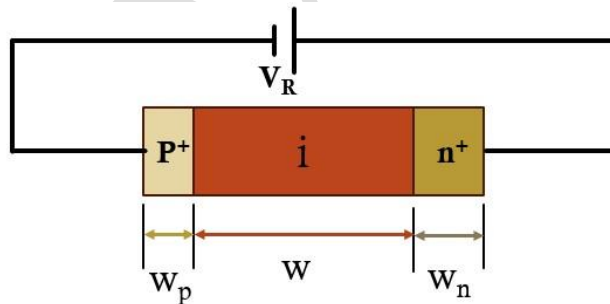

**Avalanche Photo-Diode (APD)**

The following figure explains the working of Avalanche photo-diode. It is much more sensitive than PN or PIN diodes.

The avalanche photodiode is based on the principle of avalanche multiplication of the current. It consists of heavily doped  $p^+$  and  $n^+$  regions. The depletion region is lightly doped, almost intrinsic. The diode is reverse biased using 50-300V. The light is made to incident on the depletion region. The incident light produces electron and hole pair. The electrons move towards the  $p$  region. Due to strong reverse biasing, there is depletion of charge carriers in the  $p$  region. The electrons in the  $p$  region undergo avalanche multiplication because of high reverse bias.

The holes move towards the  $p^+$  regions without producing further multiplication. The avalanche photodiode has better noise performance because the carrier multiplication is limited to electrons only.

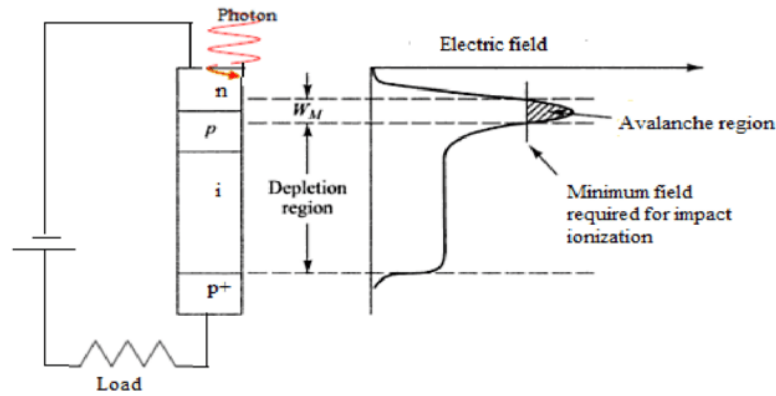

### Photo-detector

Photo-transistor is another type of photo detector. A transistor photo diode with its characteristic curves is shown in figure

### 4.11. Solar cell

It is a *p - n* junction diode which converts solar energy (light energy) in to electrical energy.

#### Construction

It consists of *p - n junction* diode made of silicon. The *p - n* diode is packed with glass window on top such that light may fall up on *p* and *n* type materials. The symbol of the solar cell is shown in figure.

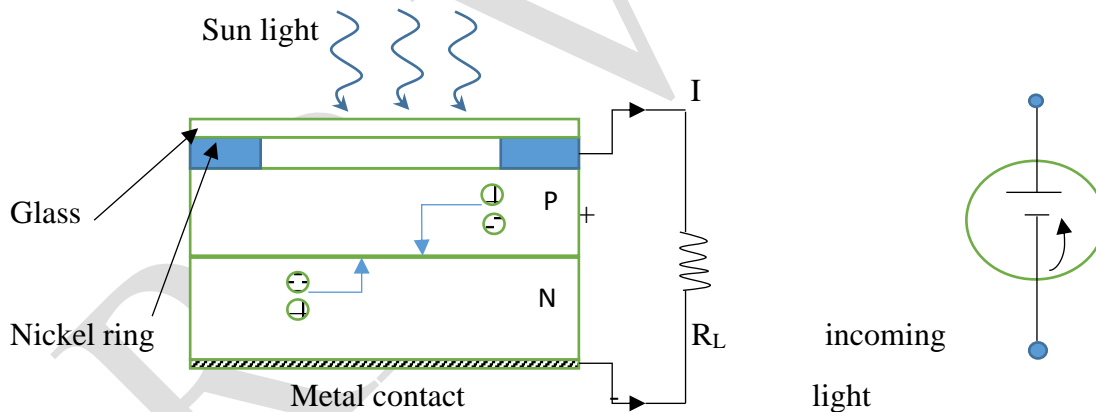

#### Working

When light radiation from sun falls on the *p - n* junction diode, the photon energy is sufficient to break the covalent bond and produce electron hole pair. These electrons and holes reach the depletion region by diffusion and they are separated by the strong barrier electrical field existing there.

The minority carrier electrons in the *p* - side cross the barrier potential to reach *n* side and the holes in *n* - side move to the *p* - side. Their flow constitutes the minority current which is directly proportional to the illumination of light and the surface area being exposed to light.

The electrons and holes accumulated on either sides of junction leads to open circuit voltage  $V_{oc}$  as a function of illumination. In case of silicon solar cell,  $V_{oc}$  is typically 0.6V and the short circuit

current is about  $40 \text{ mA/cm}^2$  in bright noon day sun light. The  $I - V$  characteristics of solar cell shows maximum power output when the solar cell is opened at the knee of the curve

### Advantage:

- (1) It operates with fair efficiency
- (2) It can be mass produced
- (3) It has high power capacity per weight
- (4) Its size is small and compact.

### Disadvantage

- (1) Solar energy is not available during winter season and night time
- (2) We need an additional equipment like inverter to store the electrical energy
- (3) The output which is in DC is converted to AC

### Uses

- (1) It is used in satellites and space vehicles to supply power to electronic and other equipment's
- (2) It is used to give power to the calculators and watches
- (3) They are used to provide commercial electricity.

## 4.12. Light Emitting Diode (LED)

### Principle

*Injection luminescence* is the principle used in LED. When  $p - n$  junction (LED) is forward biased, the majority carriers moves from  $p$  to  $n$  region and vice versa. These excess minority carriers diffuse through the junction and recombine with majority charge carriers respectively to produce (light) photons.

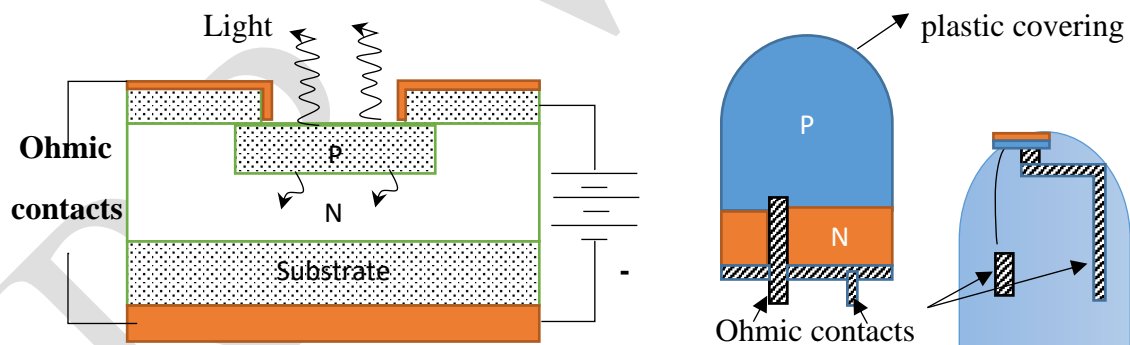

### Fabrication

Here  $n$  - type layer is grown on a substrate and  $p$  - type layer is deposited above it by diffusion.  $p$  type is grown as a top layer because of the recombination process takes in this region. For maximum light emission, a metal film anode is deposited at the outer edges of the  $p$  - type layer and the bottom of the substrate is coated with gold film (metal). This metal surface reflects the light and also act as cathode.

### Working

- (1) When a  $p - n$  junction is forward biased, the barrier width is reduced, raising the potential energy on the  $n$  side and lowering that of the  $p$  - side
- (2) The free electron and hole have sufficient energy to move to the junction region.



- (3) If a free electron recombine with a hole it will release a photon (light)
- (4) This photons created in LED are due to electron and hole recombination that are injected into the junction by a forward biasing voltage.

### **Advantages**

- (1) Smaller in size
- (2) Cost is very low
- (3) Long life time
- (4) Available in different colour at low cost
- (5) Operates at very low voltage
- (6) Fast response time ( $10^{-9}$  seconds)
- (7) Operated at wide range of temperatures (  $0 \sim 70^{\circ}\text{C}$ )
- (8) Dome shaped LED has less scattering loss

### **Disadvantages**

- (1) Power output is low
- (2) Intensity is less than laser
- (3) Light cannot travel through long distance
- (4) Light output in incoherent and not in phase

### **Dump shaped LED**

In planar LED, the reflection loss is more because of the emitted light strikes at the materials surface at an angle greater than critical angle and suffers total internal reflection. Hence it will not come out of the interface and the light is lost. Hence by making  $p$  type in hemispherical shape or by covering the  $p - n$  junction diode by a hemispherical plastic medium of higher refractive index, the reflection loss is eliminated.

## **4.13. LASER DIODES**

### **Definition**

It is specially fabricated  $p - n$  junction diodes. This diode emits laser light when it is forward biased.

### **Principle**

When the  $p-n$  diode is forward biased, the electrons from  $n$ -region and holes from  $p$ -region cross the junction and recombine with each other.

During the recombination process, the light radiation (photons) is released from a direct bandgap semiconductor like GaAs. This light radiation is known as recombination radiation. The photon emitted during recombination stimulates other electrons and holes to recombine. As a result, stimulated emission takes place and laser light is produced.

### **Construction**

- The active medium in a  $p - n$  junction diode made from a single crystal of gallium arsenide. This crystal is cut in form of a platelet having a thickness of 0.5 mm. This platelet consists of two regions  $n$ -type and  $p$ -type.

- The metal electrodes are connected to both upper (p-region) and lower (n-region) surfaces of the semiconductor diode. The forward bias voltage is applied through metal electrodes.
- Now the photon emission is stimulated in a very thin layer of  $pn$  junction.
- The end faces of the  $pn$  junction are well polished and parallel to each other. They act as an optical resonator through which the emitted light comes out.

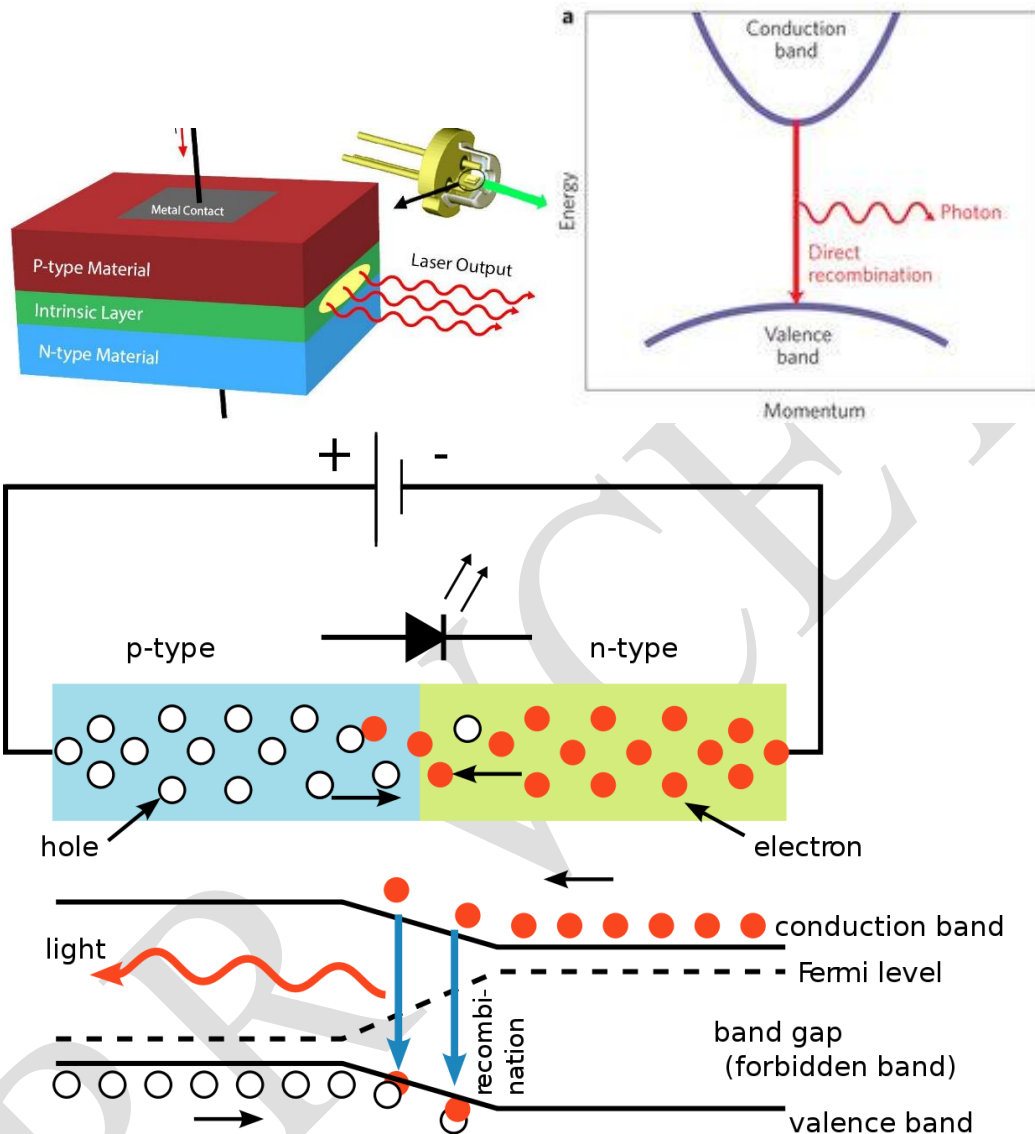

## Working

- When the  $pn$  junction is forward biased, the electrons and holes are injected into junction region.
- The region around junction consists of large number of electrons in the conduction band and holes in the valence band.
- When the forward-biased voltage is increased, more light photons are emitted. These photons trigger a chain of stimulated recombination resulting in the emission of more light photons in phase.
- These photons moving at the plane of the junction travel back and forth by reflection between two polished surfaces of the junction.
- Thus, the light photons grow in strength.
- After gaining enough strength it emits a laser beam of wavelength  $8400\text{\AA}$ .



- The wavelength of emitted radiation depends on (i) band gap & (ii) the concentration of donor & acceptor atoms.
- The wavelength of laser light is given by  $E_g = h\nu$  (or)  $\lambda = hc/E_g$  where  $E_g$  – band gap energy &  $\nu = c/\lambda$

**Characteristics**

01.	Type	Solid state homojunction semiconductor laser
02.	Active Medium	PN junction GaAs diode
03.	Pumping Method	Direct conversion method
04.	Power output	1mW
05.	Nature of Output	Continuous (or) Pulsed
06.	Wavelength	8400 Å

**Advantages**

- (i) It is small in dimension and compact
- (ii) It exhibits high efficiency
- (iii) The laser output can be increased easily by controlling junction current
- (iv) It requires little auxiliary equipment

**Disadvantages**

- (i) It is difficult to control mode pattern and structure of laser
- (ii) Output beam has large divergence
- (iii) Monochromacity is poorer than other type of laser
- (iv) Threshold current density is large

**Applications**

- (i) It is used in optical communication
  - (ii) It is used to heal the wounds by infrared radiation
- It is used in CD writing and reading

**4.9 . Organic Light Emitting Diode (OLED)**

**Principle**

An electron moves from the cathode to the emissive layer and hole moves from the anode to the conductive layer and they recombine to produce photons.

**Fabrication**

The 2 - layer OLED consists of two organic layers in between a cathode and an anode.

The two organic layers are (i) emissive layer (ii) conductive layer, made up of different conductivities. All the layers are grown over a transparent substrate, through which the light has to be emitted. Necessary biasing is given or OLE in such a way that the anode is given positive and the cathode is given negative as shown in figure.

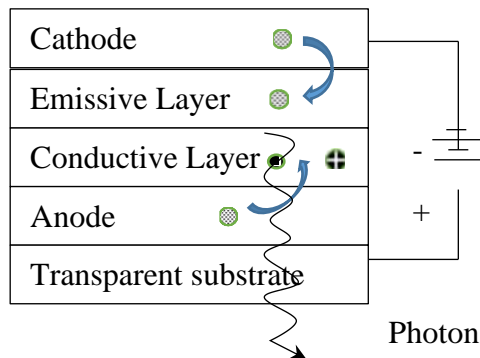

## Working

- (1) Voltage is applied across the OLED
- (2) Due to the applied voltage, the cathode gives electrons to the emissive layer
- (3) The anode withdraws the electron from the conductive layer and creates a hole in the conductive layer as shown in figure.
- (4) That is the anode gives (electron – hole) **polarons** a quasi-particle - a positive (or) negative ion slightly attracted to a negatively (or) positively charge carriers respectively.
- (5) Soon, the emissive layer has large number of negatively charged particles and the conductive layer has large number of positively charged particles.
- (6) Due to electrostatic forces between these electrons and holes, they come closer and recombine with each other.
- (7) In OLED, the recombination occurs closer to the emissive layer, because in organic semiconductors, holes move faster than electrons.
- (8) This, the recombination of electrons and holes produces photons and is emitted through the transparent substrate as shown in figure.

## Advantages

- (i) It is very thin and more flexible
- (ii) They are light in weight
- (iii) Light emission is brighter than normal LED's
- (iv) The conductive and emissive layers can be increased to increase the efficiency of OLED
- (v) OLED does not require backlighting like LCD
- (vi) They have large field of view ( about 170°C)

## Disadvantages

- (1) Manufacturing cost is high
- (2) It gets damaged easily when water falls on it
- (3) Blue OLED has less life time than Red OLED

## Applications

- (1) It is widely used in cell phones, digital cameras, etc.,
- (2) It is used in TV screens, computer monitors
- (3) Use in automotive dash boards, backlights in cars





## Types

- (1) Polymer Light Emitting diode (PLED)
- (2) Patternable Organic Light Emitting Diode (POLED)
- (3) Transparent Organic Light Emitting Diode (TOLED)
- (4) Stacked Organic Light Emitting Diode (SOLED)
- (5) Inverted Organic Light Emitting Diode (IOLED)

## 4.10. electro-Optic effects

Isotropic transparent materials such as glass do not exhibit double refraction under ordinary circumstances. However, they acquire the optical properties of a uniaxial crystal under the action of external forces. Consequently, they exhibit double refraction.

The appearance of double refraction under the influence of an external agent is known as *artificial double refraction* (or) *induced birefringence*.

The direction of the optical axis in such materials will be collinear with the direction of the external force.

The action of the external force is to cause distortion of the molecular arrangement within the material.

This in turn transforms the isotropic substance into an *anisotropic* substance. The induced birefringence disappears as soon as the external force is removed.

*The material which experience a change in their optical behaviour under the electric field are called electro-optic materials. This optical effects are known as electro-optic effects.*

### Non-linear optics

The field of study in which the matter responds in a non-linear manner to the incident light radiation is known as non-linear optics. The term nonlinear refers to a situation where the cause and effect are not linearly proportional to each other.

In certain material, the intensity and frequency of the incident light input is not linearly proportional to that of the output and those materials are referred as non-linear materials.

The development of optical properties such as refractive index on the electric and magnetic fields associated with light is known as non-linear effect

We know that a light wave is electromagnetic in nature i.e., it consists of electric and magnetic fields.

When the light propagates through a material, it changes the properties of the medium, such as the refractive index. The change depends on the electric and magnetic fields associated with the light.

For example, non-linear effects cannot be observed with the ordinary light beam of low intensity. It is due to the reason that the electric and magnetic fields associated with the light beams is very weak.

With the invention of laser, it is now possible to have electric fields which are strong enough to observe interesting non-linear effects.

### Non-linear properties

Few of the non-linear phenomena observed are:

1. Second harmonic generation
2. Optical mixing
3. Optical phase conjugation
4. Soliton
5. Parametric amplification
6. Self-focussing.

## 4.11. Second Harmonic Generation

In a linear medium, polarization  $P$  is directly proportional to the electric field  $E$  that induces it.

$$P \propto E$$

$$(or) P = \epsilon_0 \chi E$$

$\epsilon_0$  – permittivity of free space



$\chi$  – electrical susceptibility

In nonlinear medium for higher fields i.e., higher intensities of light the relationship between the electric polarization  $P$  and the electric field fails to be linear and non-linear effects are observed

$$P = \epsilon_0 (\chi_1 E + \chi_2 E^2 + \chi_3 E^3 + \dots)$$

Where  $\chi_1$  is the linear susceptibility and  $\chi_2, \chi_3, \dots$  are higher order non-linear susceptibilities. With increase of field, the higher order terms come into play.

## Modulation of light

*Modulation is the process of varying one of the parameters such as amplitude, intensity, frequency, phase and polarization of a carrier wave in accordance with signal to carry the signal information*

But the optical detectors respond only to the intensity (or) irradiance of the light. Thus, only intensity modulators at optical frequencies are used.

*Demodulation means the reverse process of modulation i.e., extraction of the original signal from the modulated carrier, detected at the receiver.*

The two schemes used to modulate the optical signals in LED or LASER diodes are:

- (i) Direct modulation (ii) External modulation

### (i) Direct modulation

In the direct modulation an electronic circuit is designed to simply modulate the current injected into the device (LED, LASER diode)

The optical output is controlled by the injected current, the desired amplitude (Intensity) modulation is obtained.

The driver for this direct modulation may be a FET or an HBT hetero bipolar transistor. The structure of the electronic and opto-electronic devices (LED, LASER diodes) are different hence, these devices cannot be fabricated on the same chip. The direct modulation has several problems. Limit in upper modulation frequencies (nearly 40 GHz). There is a shift in emission frequency.

### (ii) External modulation

In the external modulation scheme, the light passes through a material whose optical properties can be modified externally. The electro-optic, acoustic-optic, or magneto-optic modulators are example for the external modulator.

The electro-optic effect is most widely used for high speed applications. It is most comparable with modern electronics. The electro-optic effect involves the change in the refractive index of the material by an electric field.

In the most of the semiconductors, the electro-optic effect is quite small. Hence extremely high fields are needed to cause optical modulation. Lithium-niobate is the most widely available electro-optic material. But it is not a semiconductor.

It is found that the electro-optic effect is very strong in quantum wells made from GaAs / AlGaAs. Hence the quantum-well modulators plays a prominent role in the optical modulation.

## Modulators

These are used to modulate the intensity or phase of light by an electric field. The different electro optic modulators are

- (a) Electro-optic modulators based on Kerr effect
- (b) Electro-optic modulators based on Pockels effect
- (c) Electro absorption modulator- by Franz Keldysh and stark effect
- (d) Quantum well electro absorption modulator

## 4.12. KERR EFFECT

Optical anisotropy induced in an isotropic liquid under the influence of an electric field is known as the Kerr effect.

A Kerr cell is required for studying the effect. It consists of a sealed glass cell filled with a liquid comprising of asymmetric molecules. Two plane electrodes of length  $L$  are arranged parallel to each other.

When a voltage is applied to the electrode a uniform electric field is produced in the cell. The Kerr cell is placed between a crossed polarizer systems. The molecules of the liquid tend to align along the electric field direction.

As the molecules are asymmetric, the alignment causes anisotropy and the liquid becomes double refracting. The induced birefringence is proportional to the square of the applied electric field ( $E$ ) and to the wavelength of incident light ( $\lambda$ ). Thus,

$$\Delta\mu \propto \lambda \quad (\text{or}) \quad \Delta\mu \propto E^2 \quad (\text{or}) \quad \Delta\mu = K \lambda E^2$$

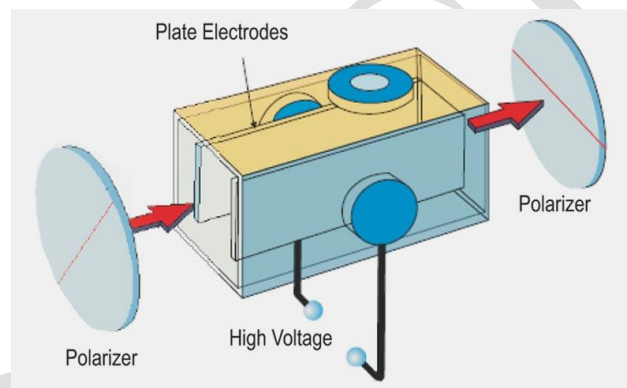

Where  $K$  is known as Kerr constant

The vibration direction of plane polarized light passing between crossed polarizer is rotated. Among the liquids, nitrobenzene has high Kerr constant and hence it is used in the cell.

Kerr cell is used as (i) an electro-optic shutter in high-speed photography. (ii) a light chopper in the measurement of the speed of light.

## Pockels effect

*F. Pockels discovered in 1893 that the application of an electric field to piezoelectric crystals makes them birefringent.* Normally, piezoelectric crystals are birefringent but in certain directions do not exhibit double refraction.

When an electric field is applied along these directions, double refraction is induced along these directions also.

A Pockels cell consists of a piezoelectric crystal, for example lithium niobate placed between crossed polarisers. Transparent electrodes (thin conducting coatings of tin oxide or indium) are deposited on opposite sides of the crystal.

The crystal is oriented with its optic axis along the direction of the electric field. The transparent electrodes ensure free propagation of light through the crystal. A Pockels setup is shown in figure.

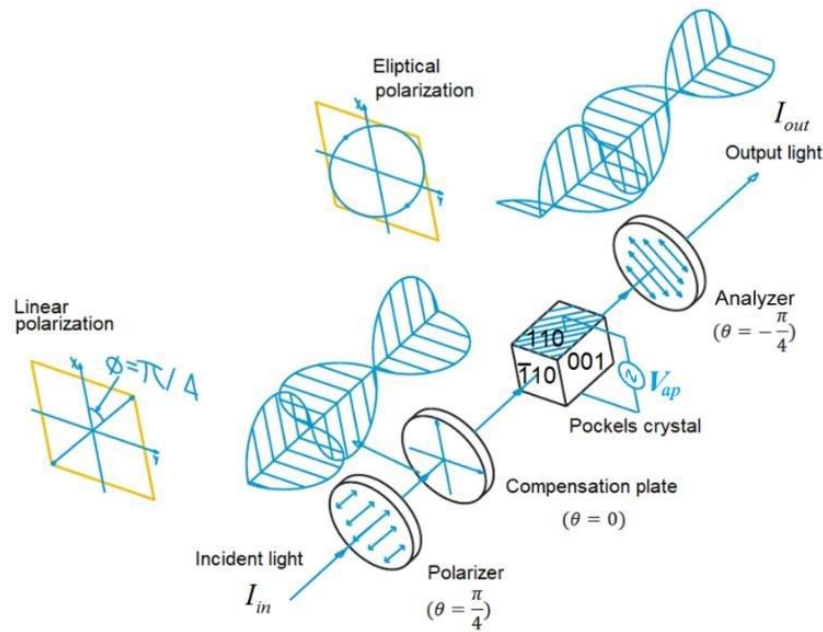

The birefringence induced in the crystal is proportional to the strength of the applied field. Thus,

$$\Delta\mu \propto E \text{ (or) } \Delta\mu = kE$$

Where  $k$  is a constant depends on characteristic of the material. The above equation shows that Pockels effect is a linear effect. The total birefringence of the cell is initially made equal to  $\lambda/2$ . When the electric field is increased, the beam is transmitted or hindered depending on the phase difference between the o-ray and e-ray

The device switches on and off periodically. Pockels cells are used in fast switching applications and in fiber optics. It can be used to obtain amplitude, frequency or phase modulation.

The piezoelectric crystals of ammonium dihydrophosphate (ADP) and potassium dihydrophosphate (KDP) are widely used in Pockels cell. Kerr and Pockels cells are widely used as electro-optic shutters in Q-switching of lasers.

#### 4.12. Franz – Keldysh and Stark Effect Electro-absorption

Generally, semiconductors absorb the photon when the photo energy is equal to or greater than the band gap energy ( $E_g$ ) of the semiconductor.

In some cases the doped impurities in the semiconductor may also absorb the photons. For this absorption, the energy of the photon must be at least equal to the ionization energy of the impurity atom. This low energy donor band and acceptor band absorption transitions have been observed in many semiconductors.

##### (i) Franz-Keldysh effect

The absorption of light photons having energies less than the band gap energy of the semiconductor by applying a strong electric field is called as Franz-Keldysh effect.

Figure shows the bending of energy bands due to the presence of electric field. When there is no photon and the electric field, the wave function of electron at A (valence band) and B (conduction band) are decaying without overlapping in the band gap. The increase of electric field ( $E$ ), decreases the distance AB and hence the overlapping of wave functions within the energy gap increases

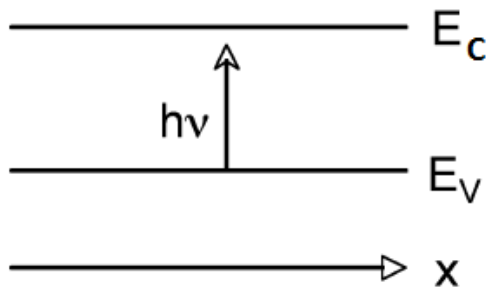

a) without electric field

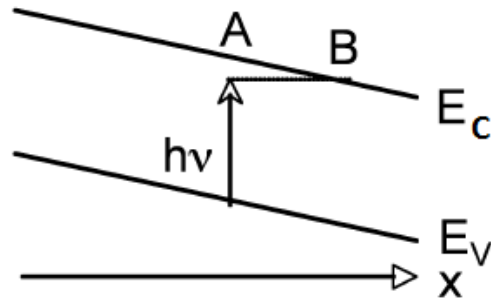

b) with electric field

When there is no photon, the valence electron has to tunnel through a triangular barrier of height  $E_g$  and thickness  $(d) = E_g / qE$

By absorption of photon having energy  $hv < E_g$ , the thickness is reduced to  $\frac{E_g - hv}{qE}$ . Therefore, the overlapping of the wave functions further increases and the electron from valence band can easily tunnel to the conduction band. Thus, an absorption of photon having energy  $hv < E_g$  in the presence of strong electric field produces electron tunnelling.

Thus the Franz-Keldysh effect is a photon assisted tunnelling of electron through the barrier. The absorption of photon by the electron depends on the strength of applied field.

Generally, the Franz-Keldysh effect occurs when the applied electric field  $E$  is more than  $10^7 \text{ Vm}^{-1}$ .

### (ii) Stark effect

The energy level splitting of the outer  $2s$  or  $2p$  states and hence absorption of photon whose energy is less than the band gap by an applied electric field is called Linear stark effect.

Energy level splitting of the outer  $2s$  or  $2p$  states and hence absorption of photon whose energy is less than the band gap by an applied electric field is called Linear stark effect.

Energy level splitting of ground level ( $1s$ ) states and hence absorption of photon whose energy is less than the band gap by an applied electric field is known as quadratic or second order stark effect.

Thus the Franz-Keldysh effect and Stark effect refer to the electron tunnelling via electro-absorption.

Using these effects the modulation of light can be done by applying sequence of electric pulses. These type of modulators are called electro-absorption modulators. Consider the light photon energy smaller than the band gap of semiconductor. When there is no applied field, the light photon is completely transmitted without any absorption.

When the bias pulses are applied which correspond to the signal to be transmitted, there is attenuation of transmitted light depending upon the value of magnitude of applied bias pulses.

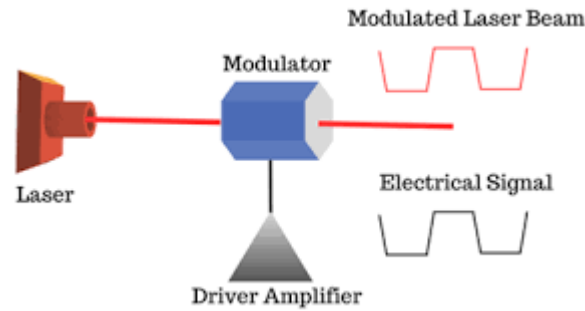

### Drawbacks

1. The electro-absorption effects are very weak.
2. To increase the electro-absorption effect, very large electric fields ( $10^7$  V/m) or very long devices (several millimetres) are needed.

Hence these electro-absorption effects are not used to modulate the light since the applied field signal is not very large.

### 4.13. Quantum well electro-absorption modulators

The electron in a potential well of infinite depth cannot escape through the walls of the potential well. Thus, the electron is confined in the region defined by the well width. Further its energies are quantised.

Figure shows the ground state wavefunctions of the hole and hole sub band with zero field. Taking  $E_{ph}$  = absorbed photon energy,  $E_e$  and  $E_H$  are the electron and hole sub band energies,  $E_{ex}$  = binding energy of exciton and  $E_{g(well)}$  = bandgap energy between conduction band and valence band. The transition energy is given by finite transverse electric field.

When there is an applied transverse electric field ( $10^7$  V/m), the bending of quantum well takes place. Further the electron and hole wave functions are pushed toward the opposite sides of the well

$$E_{ph} = E_e + E_h + E_{g(well)} - E_{ex}$$

There is a little change in  $E_{ex}$  and a very small change in  $E_{g(well)}$  due to stark effect in the well material. But due to the modification in the envelope of the wave functions of hole and electron, there is a reduction in  $E_e$  and  $E_h$  the sub band energies.

A quantum well is a potential well with thick walls ( $\approx 100 \text{ \AA}$ ). The electrons and holes (particles) are confined in the region defined by the well width. Similarly there is also multiple quantum well formed by two or more lattice matched materials.

So the ground state inter-sub band energy separation is very small. This results in a shift of the absorption spectrum to lower energies. This shift is the dominant effect which results a pronounced red shift of the absorption edge. This shift is called Quantum Confined Stark Effect (QCSE). This shift is larger than the stark shift (or) Franz-Keldysh effect in bulk semiconductors.

This enormous shift is due to small size ( $100 \text{ \AA}$ ) of quantum well. *The shift is proportional to square of the electric field and to fourth power of the quantum well width.* This effect is utilised to design efficient electro-absorption light modulators.

When the energy of the incident photon is (20meV) below the heavy hole exciton absorption (50 meV) at zero applied electric field, there is no absorption of the incident light. SO the input light is completely transmitted through the quantum well material.

When there is an applied transverse field of  $10^7$  V/m (or) a transverse applied voltage of about 1 volt in the quantum well material the heavy hole exciton absorption edge shifts and coincides with the photon energy. This results in strong absorption. Therefore there is an efficient intensity modulation of light.

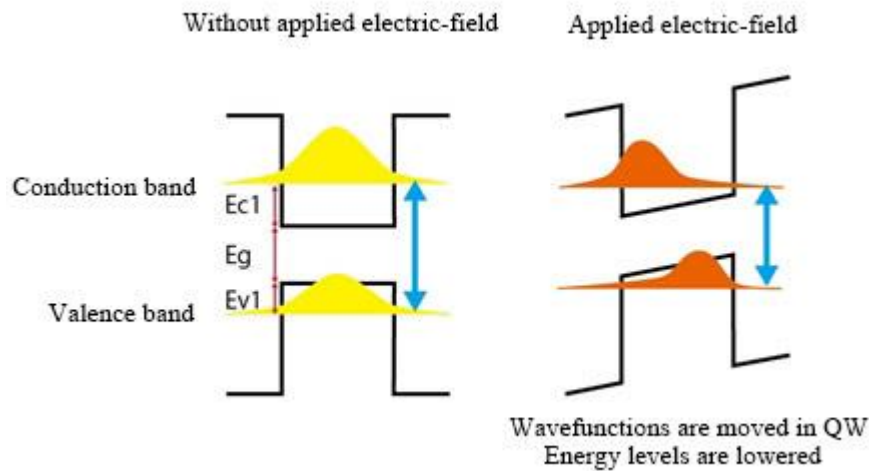

#### 4.14. p-i (MQW)- n diode quantum well electro-absorption modulator

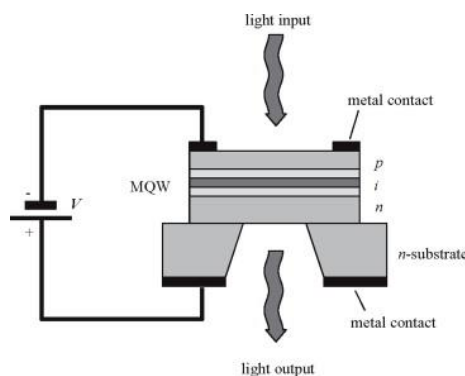

#### Construction and working

Figure shows the schematic diagram of p-I (MQW)-n diode quantum well electro-absorption modulator. It is a mesa-etched GaAs modulator. The total thickness of Multi Quantum Well region is about  $1\ \mu\text{m}$  and the diameter of the mesa diode is about  $50$  to  $100\ \mu\text{m}$ .

The optical window (i.e., entrance gate for incident light) is situated at the top of the p-i-n diode is about half of the diode area. The p-i-n diode is made by photo lithography, selective etching and ohmic contact formation.

Since the GaAs substrate is not transparent to light, it is selectively etched under the active region of the diode. The light is transmitted through the diode or normal to the plane of the quantum well layers.

It is available in the form of integrated and waveguide form. Due to the waveguide structure and optical confinement, there is a single mode transmission.

Since the p-i-n diode is reverse biased, when there is no applied transverse electric field, there is no flow of current in the external circuit. When there is an applied transverse field (or bias signal), the incident light photon is absorbed and corresponding there is an increased current flow in the external circuit.

Thus the modulation of light takes place which is proportional to the applied transverse electric field or bias signal strength. The modulation band width of  $40\ \text{GHz}$  can be obtained because of very small time constant of the device.



## 4.15. Optical switching

The optoelectronic switching devices are very useful for computing and light activated logic gates applications. Optical or photonic switching refers to a phenomenon in which transmission of an optical field through a device is switched among two or more possible states by optical means.

### Types of optical switching

There are two types of optical switching such as linear optical switching and non-linear optical switching. The Quantum Controlled Stark Effect (QCSE) in  $p-i-n$  (Multi Quantum Well)  $-n$  (p-type-intrinsic-n-type) diode is used for linear optical switching. Optically controlled switching and logic devices are based on the QCSE.

Quantum confined stark effect refers to the bending of potential well due to transverse applied electric field and shifting of the absorption edge of exciton to lower energy side and resulting absorption of photons whose energy is less than the original exciton absorption peak energy.

*The quantum wells can be reduced in their size as quantum wires and quantum dots. Quantum dots are the nanometre size box like structure. When the electrons are confined in 10 nm scale 3-D semiconductor heterostructures, the electron motion is fully quantized which creates artificial atomic states in semiconductors.*

*The quantum dots provide the quantum computers which are faster and provide more memory than conventional computers. Each quantum dot consists of about 20 electrons and acts as an optical switch. Here GaAs is the basic material. The spin direction of electron is mainly taken into account for on-off condition*

The non-linear optical switching is based on the self-phase modulator (SPM). The transmission of light through the device is intensity dependent so that the optical beam itself induces a switching depending on its intensity. This phenomenon is called self-phase modulation and it exhibits in optical fibre.

In a short piece of optical fibre, its ends are made highly reflecting through suitable thin film coating. This device is used to select a particular channel in a multichannel optical communication system. The phase shift introduced by the above fibre depends on intensity and power of the light beam. The non-linear optical switching provides a faster switching time  $10^{-15}$  second.

## 4.16. Self-Electro Optic Effect Device (SEED)

In  $p-i(MQW)-n$  diode, when the reverse bias voltage increases to a large value, the tunnelling current varies remarkably.

The photocurrent-bias voltage characteristic curves, exhibits negative differential resistance (NDR) region. The NDR occurs where the heavy-hole (HH) and the light-hole (LH) absorption peaks cross the photon energy of the input light.

This NDR effect is exploited in SEED. Thus the SEED device exhibits photonic switching, bi-stability and optically induced oscillations.

*Slope at NDR range is negative i.e., photocurrent decreases with increase of bias voltage.*



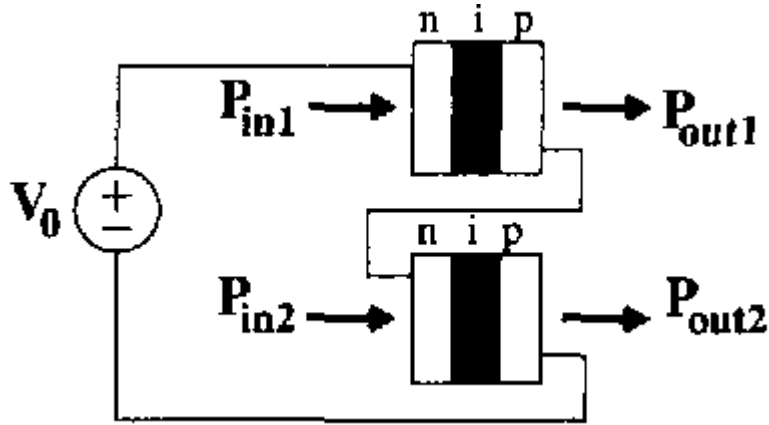

Figure shows the  $p$ - $i$ (MQW)- $n$  diode in the reverse bias with a series resistor.  $P_{in}$  is incident optical power and  $P_{out} = I^2 R_s$  is electric output power. Here  $I$  is the photocurrent flowing through resistance  $R_s$ .

### Working

At low bias voltages and low optical power most of the incident light is transmitted. But the photo current increases due to recombination of electrons and holes.

When the incident optical power increases, the photocurrent ( $I$ ) increases due to tunnelling of charge carriers. Thus the voltage drop  $I^2 R_s$  across the series resistor increases.

Since the supply voltage remains constant, the negative bias across the diode decreases. The heavy hole absorption peak is shifted to higher energies.

Therefore the transmission of light is decreased. This will result more amount of light absorption and increased value of photocurrent due to tunnelling.

Thus the increase of the input optical power increases the output electric power.

At particular input optical power, the heavy hole and light hole absorption peaks cross the photon energy of the input light. Hence there is no absorption of light by exciton or heavy hole or light hole

Thus the photo current decreases and correspondingly output electric power is also decreased.

Thus the negative resistance region (NDR) arises. Further, increase of input optical power increases the output electric power due to ordinary photon absorption by the diode

Thus the state of the device is altered by optical power. That is photonic or optical switching is obtained by light beams with two different powers one for complete transmission and other one for control (zero transmission of light)

The hysteresis observed in the curve is due to the asymmetric shapes of the heavy hole and light hole absorption curves. The feedback due to the series resistor is optoelectronic type.

### 4.17. Electro-optic Switch based on NLO material

An example of an electro-optic switch based on NLO materials is shown in figure. The switch is comprised of two parallel waveguides made of NLO materials. The waveguide channels have a different refractive index from the surrounding material. The light can be switched back and forth between the channels by applying and removing a voltage across the bottleneck. In the absence of an electric field, the light travelling through the lower wavelength interacts with the upper waveguide in a non-linear manner at the bottleneck, causing the light to switch channels.

Switching *does not* occur when an electric field is applied. The electric field polarizes the NLO material and alters the refractive indices of the two channels, such that the non-linear interaction at the bottleneck is modified and the light stays in the lower waveguide.

## Plasmon

A plasmon is a quantum of plasma oscillation. Just as light (an optical oscillation) consists of photons, the plasma oscillation consists of plasmons. The plasmon can be considered as a quasiparticle since it arises from the quantization of plasma oscillations.

Thus, plasmons are collective oscillations of the free electron gas density. For example, at optical frequencies, plasmons can couple with a photon to create another quasiparticle called a plasmon polariton.

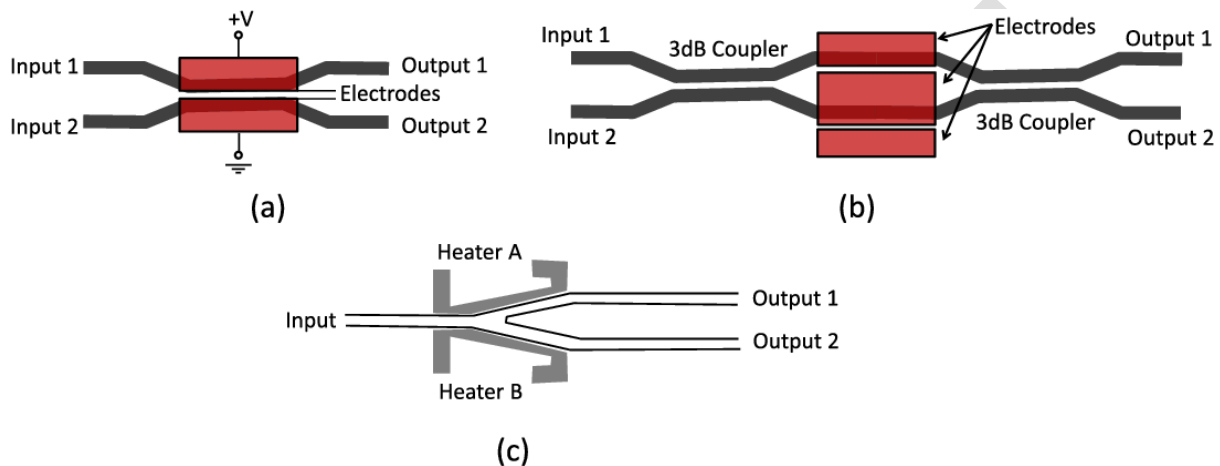

## Part – A

### 1. What are optical materials?

The materials which are sensitive to light are known as optical materials. These optical materials exhibit a variety of optical properties.

### 2. What are the types of optical materials?

Based on nature of propagation of light, the optical materials are classified as

- (i) Transparent
- (ii) Translucent
- (iii) Opaque

### 3. What is transparent materials?

The materials which transmit light with little absorption and reflection. In these materials, one can clearly view the object through the material

### 4. What is translucent materials?

The incident gets scattered within the material and the diffused light is transmitted with the other side of the material. One cannot clearly view the object through this material

### 5. What is opaque materials?

The material which absorbs the visible light are called opaque. Here, after interaction of light with material, the light gets reflected or absorbed.

### 6. Define carrier generation and recombination process.



Generation is the process of creating electron and hole pair per volume-second. While the recombination is the process of annihilating the electron and hole pair per unit volume – second.

**7. List out the types of carrier generation?**

- (1) Photon generation
- (2) Phonon generation
- (3) Impact Ionization

**8. List out the types of Recombination?**

- (1) Radiative recombination
- (2) Shockley - Read - Hall recombination
- (3) Auger recombination

**9. What is the effect of optical absorption in semiconductors?**

- (1) It forms excitons
- (2) It produce photoconductivity
- (3) It excites the crystal lattice vibrations
- (4) It excites the free electrons and holes

**10. Define trap, its origination and types**

It is an intermediate energy levels presents in the energy band gap. These traps arises due to the presence of impurity atoms and imperfections in the crystal. There are two types of trap viz. (1) Trapping centre an (2) Recombination centre

**11. Differentiate Trapping centre and Recombination centre**

S.No	Trapping centre	Recombination centre
1.	It is a type of trap which captures an electron (or) hole and then reexcite to free state	It is type of trap in which electron an hoke recombines with eachother to produce phonons
2.	Here the charge carriers are temporarily trapped	Here the charge carriers are permanently trapped

**12. What is meant by injection luminescence? Give example**

When the majority carriers are injected from *p* to *n* and *n* to *p* region, they become excess minority carriers. Then these excess minority carriers diffuses away from the junction and recombines with the majority carriers in *p* and *n* regions and emits light. This phenomenon is known as injection luminescence. Example: LED

**13. What is solar cell?**

It is basically a large area photo diode which converts sunlight (solar energy) directly in to electricity (electrical energy), with larger efficiency of photon absorption..

**14. Explain the term exciton?**

An exciton can form when a photon is absorbed by a semiconductor. This excites an electron from the valence band into the conduction band. In turn, this leaves behind a positively charged electron hole . The electron in the conduction band is then effectively attracted to this localized hole by the repulsive Coulomb forces from large numbers of electrons surrounding the hole and excited electron.

**15. What is LED?**

It is a *P-N* junction which emits light when it is forward biased.



**16. Why is the shape of LED made hemispherical (or) why dome shape LED is preferred than a planar LED.**

In planar LED's the emitted light strikes the material interface at an angle greater than the critical angle and the reflection loss will be very high.

Therefore, to minimise the reflection loss, hemispherical dome shape LED is made, in which the angle at which the emitted light strikes the interface can be made less than the critical angle.

**17. What is an OLED?**

It is solid state device made up of thin films of organic molecules that produce light with the application of electricity.

**18. What is the principle of OLED?**

An electron moves from the cathode to the emissive layer and the hole moves from the anode to the conductive layer and they recombine to produce photons. This is the principle used to emit light in OLED.

**19. Mention any four types of photo diodes**

- (1) PIN photo diode
- (2) Avalanche photo diode
- (3) Schottky photo diode
- (4) Solar cell

**20. What is laser diode?**

It is specially fabricated *p-n* junction diode. This diode emits laser light when it is forward-biased.

**21. What is Franz-Keldysh effect?**

The change in absorption in a semiconductor in the presence of a strong electric field is called *Franz-Keldysh* effect. Since the energy of photon  $h\nu$  is less than energy gap, there is no absorption of photon in the absence of electric field. But in the presence of a strong electric field bending of bands occurs and the tunneling probability of photon absorbed electron from valence band to conduction band increases. Thus due to application of the field absorption changes.

**22. What is Stark effect?**

The change in atomic energy upon the application of an electric field is called the stark effect. The electric field affect the higher order, or outer orbits of electrons and splitting of energy states occur. This reduces the bandgap.

**23. What is meant by electro absorption?**

Both Franz-Keldysh and Stark effects results in absorption of photons with energies smaller than the bandgap with the application of an electric field. This phenomenon is known as electro-absorption.

**24. What is meant by quantum confined Stark effect?**

In quantum well structure, with the application of an electric field, the electron and hole wavefunctions are separated and pushed towards opposite sides of the well. The reduced overlap results in corresponding reduction in absorption This result in a shift of the absorption spectrum to longer wavelength (red shift). This shift is known as the quantum confined Stark effect.

**25. What is electro optic effect?**

Changing the refractive index and other optical characteristics of a medium by the application of electric field is called *electro-optic effect*.

**26. What are Pockel's effect and Kerr effect?**

Due to electro-optic effect the refractive index of a material changes with applied field as

$\Delta \left[ \frac{1}{n^2} \right] = rE + pE^2$  where  $r$  is the linear electro optic coefficient.  $P$  is the quadratic electro optic coefficient. The linear variation of the refractive index is called Pockels effect and a quadratic variation is called Kerr effect.

**Part – B**

**1. Explain carrier generation and recombination in semiconductor**

**Carrier generation:**

It is the process of generating number of hole - electron pairs per unit volume second. Basically there are three types of carrier generations.

**(i) Photo generation**

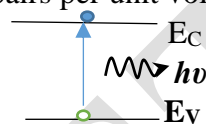

When a photon is incident with energy  $h\nu$  greater than the energy of band gap of a semiconductor, then the electrons in valence band absorb this photon and jump to conduction band thereby generating electron - hole pair. For different wavelengths of light with different energies it can take an electron in higher conduction band states.

**(ii) Phonon generation**

When a semiconductor is under thermal excitation, with increase of temperature of the semiconductor, lattice vibrations increase which give rise to more phonons. Due to more lattice vibrations, covalent bonds in the semiconductor break down and electron - hole pairs are generated.

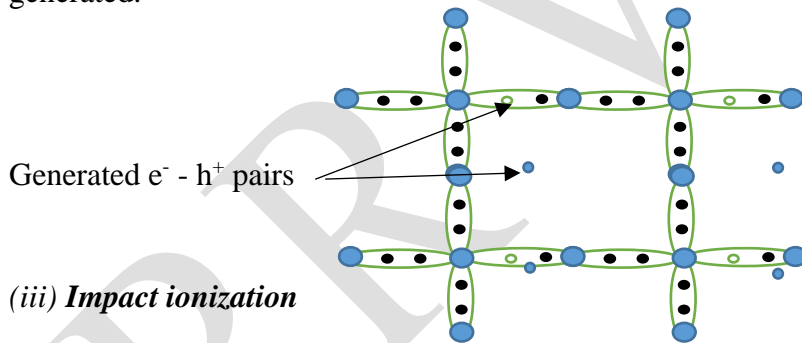

**(iii) Impact ionization**

When a semiconductor is under an electric field, one energetic charge carrier will create another charge carrier. For a very high electric field, it results in an avalanche breakdown.

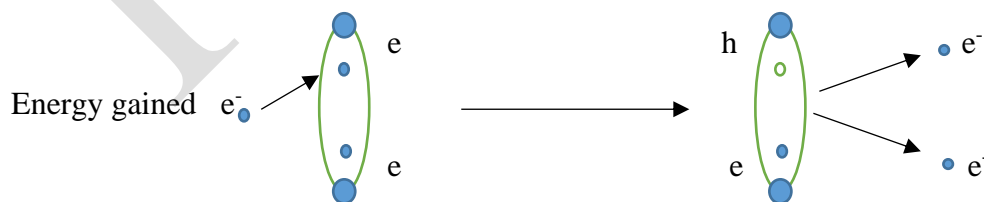

**Recombination:**

It is a process in which the electron – hole pair are annihilated during recombination per volume second. Recombination occurs in three ways:

**(i) Radiative recombination**

This process occurs in direct band gap semiconductor. When an electron in the conduction band minimum falls to valence band maximum without change in momentum. One photon of energy

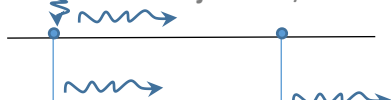

$h\nu$  is emitted. This is direct recombination. Here the electrons in the highest energy states of conduction band will come back to conduction band minimum by non radiative transition (heat).

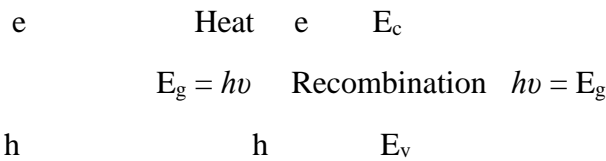

**(ii) Shockley - Read - Hall recombination**

In this process, electrons from the conduction band minimum or holes from the valence band maximum are come to a defect level intermediate between  $E_c$  and  $E_v$  by radiation energy as photons or phonons. These intermediate levels are called trapping level. Hence either the electron or the hole from the trapping level returns to the valence band or conduction band. They are not set free & hence it is said to be trapping level. Generally this process occurs in impure semiconductors.

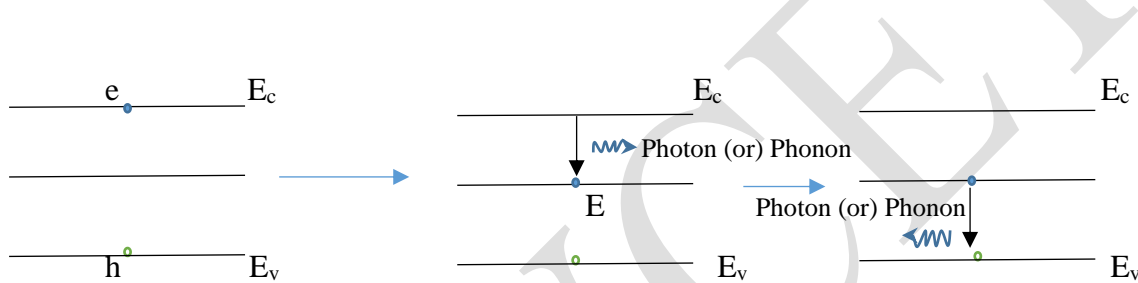

**(iii) Auger recombination**

Here three carriers are involved. i.e., the electron and hole recombine may have an energy which is given to the third free electron in the conduction band. Then the excite third electron comes back to the conduction band edge by emitting energy as heat. Generally an Auger recombination occurs for heavily doped material.

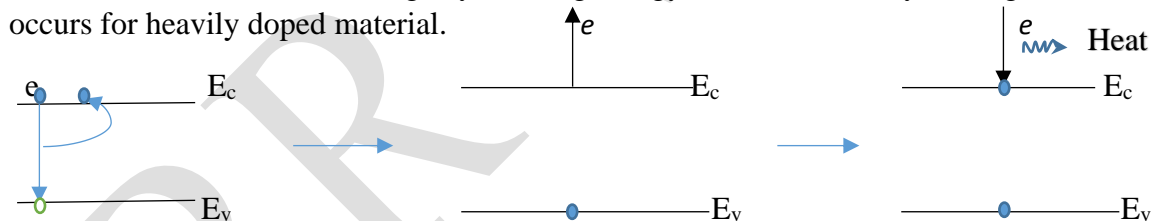

**2. Explain the construction and working of solar cell. Also discuss the advantages, disadvantages and its applications.**

It is a  $p - n$  junction diode which converts solar energy (light energy) in to electrical energy.

**Construction**

It consists of  $p - n$  junction diode made of silicon. The  $p - n$  diode is packed with glass window on top such that light may fall up on  $p$  and  $n$  type materials. The symbol of the solar cell is shown in figure.

The thickness of  $p$  and  $n$  regions are kept very small. As a result electrons or holes generate near the surface of  $p$  or  $n$  region can diffuse to the junction before they recombine. A nickel ring is provided at the top of the  $p$  layer which acts as the positive output terminal. A metal contact at the bottom serves as the negative output terminal.

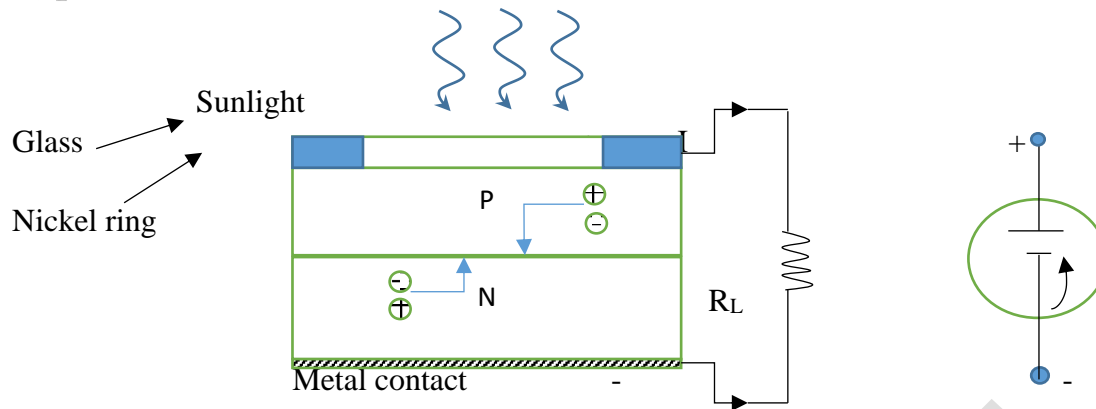

### Working

When light radiation from sun falls on the  $p - n$  junction diode, the photon energy is sufficient to break the covalent bond and produce electron hole pair. These electrons and holes reach the depletion region by diffusion and they are separated by the strong barrier electrical field existing there.

The minority carrier electrons in the  $p$  - side cross the barrier potential to reach  $n$  side and the holes in  $n$  - side move to the  $p$  - side. Their flow constitutes the minority current which is directly proportional to the illumination of light and the surface area being exposed to light.

The electrons and holes accumulated on either sides of junction leads to open circuit voltage  $V_{oc}$  as a function of illumination. In case of silicon solar cell,  $V_{oc}$  is typically  $0.6V$  and the short circuit current is about  $40 \text{ mA/cm}^2$  in bright noon day sun light. The  $I - V$  characteristics of solar cell shows maximum power output when the solar cell is opened at the knee of the curve

### Advantage:

- (5) It operates with fair efficiency
- (6) It can be mass produced
- (7) It has high power capacity per weight
- (8) Its size is small and compact.

### Disadvantage

- (4) Solar energy is not available during winter season and night time
- (5) We need an additional equipment like inverter to store the electrical energy
- (6) The output which is in DC is converted to AC

### Uses

- (4) It is used in satellites and space vehicles to supply power to electronic and other equipment's
- (5) It is used to give power to the calculators and watches
- (6) They are used to provide commercial electricity.

### 3. Explain the construction and working of a LED with energy band diagram. How the Planar LED is differ from dump shaped LED?

#### Principle

*Injection luminescence* is the principle used in LED. When  $p - n$  junction (LED) is forward biased, the majority carriers moves from  $p$  to  $n$  region and vice versa. These excess minority carriers diffuse through the junction and recombine with majority charge carriers respectively to produce (light) photons.

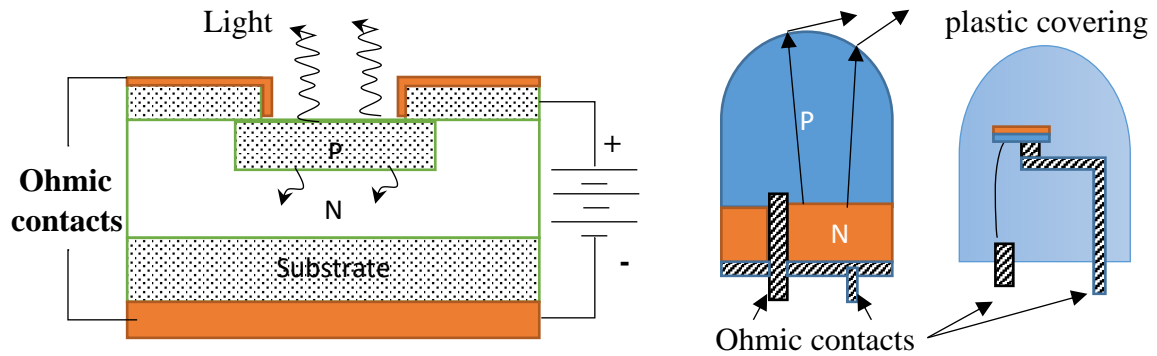

### Fabrication

Here  $n$  - type layer is grown on a substrate and  $p$  - type layer is deposited above it by diffusion.  $p$  type is grown as a top layer because of the recombination process takes in this region. For maximum light emission, a metal film anode is deposited at the outer edges of the  $p$  - type layer and the bottom of the substrate is coated with gold film (metal). This metal surface reflects the light and also act as cathode.

### Working

- (1) When a  $p - n$  junction is forward biased, the barrier width is reduced, raising the potential energy on the  $n$  side and lowering that of the  $p$  - side
- (2) The free electron and hole have sufficient energy to move to the junction region.
- (3) If a free electron recombine with a hole it will release a photon (light)
- (4) This photons created in LED are due to electron and hole recombination that are injected into the junction by a forward biasing voltage.

### Advantages

- (1) Smaller in size
- (2) Cost is very low
- (3) Long life time
- (4) Available in different colour at low cost
- (5) Operates at very low voltage
- (6) Fast response time ( $10^{-9}$  seconds)
- (7) Operated at wide range of temperatures (  $0 \sim 70^{\circ}\text{C}$  )
- (8) Dome shaped LED has less scattering loss

### Disadvantages

- (1) Power output is low
- (2) Intensity is less than laser
- (3) Light cannot travel through long distance
- (4) Light output in incoherent and not in phase

### Dump shaped LED

In planar LED, the reflection loss is more because of the emitted light strikes at the materials surface at an angle greater than critical angle and suffers total internal reflection. Hence it will not come out of the interface and the light is lost. Hence by making  $p$  type in hemispherical shape



or by covering the  $p - n$  junction diode by a hemispherical plastic medium of higher refractive index, the reflection loss is eliminated.

#### 4. Write a brief note on OLED?

##### Principle

An electron moves from the cathode to the emissive layer and hole moves from the anode to the conductive layer and they recombine to produce photons.

##### Fabrication

The 2 - layer OLED consists of two organic layers in between a cathode and an anode.

The two organic layers are (i) emissive layer (ii) conductive layer, made up of different conductivities. All the layers are grown over a transparent substrate, through which the light has to be emitted. Necessary biasing is given to OLE in such a way that the anode is given positive and the cathode is given negative as shown in figure.

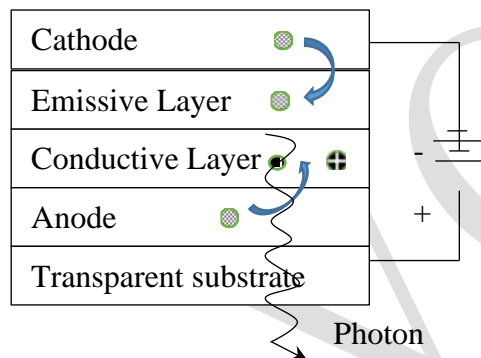

##### Working

- (1) Voltage is applied across the OLED
- (2) Due to the applied voltage, the cathode gives electrons to the emissive layer
- (3) The anode withdraws the electron from the conductive layer and creates a hole in the conductive layer as shown in figure.
- (4) That is the anode gives (electron – hole) **polarons** a quasi-particle - a positive (or) negative ion slightly attracted to a negatively (or) positively charge carriers respectively.
- (5) Soon, the emissive layer has large number of negatively charged particles and the conductive layer has large number of positively charged particles.
- (6) Due to electrostatic forces between these electrons and holes, they come closer and recombine with each other.
- (7) In OLED, the recombination occurs closer to the emissive layer, because in organic semiconductors, holes move faster than electrons.
- (8) This, the recombination of electrons and holes produces photons and is emitted through the transparent substrate as shown in figure.

##### Advantages

- (i) It is very thin and more flexible
- (ii) They are light in weight



- (iii) Light emission is brighter than normal LED's
- (iv) The conductive and emissive layers can be increased to increase the efficiency of OLED
- (v) OLED does not require backlighting like LCD
- (vi) They have large field of view ( about 170°)

## Disadvantages

- (1) Manufacturing cost is high
- (2) It get damaged easily when water falls on it
- (3) Blue OLED has less life time than Red OLED

## Applications

- (1) It is widely used in cell phones, digital cameras, etc.,
- (2) It is used in TV screens, computer monitors
- (3) Use in automotive dash boards, backlights in cars

## Types

- (1) Polymer Light Emitting diode (PLED)
- (2) Patternable Organic Light Emitting Diode (POLED)
- (3) Transparent Organic Light Emitting Diode (TOLED)
- (4) Stacked Organic Light Emitting Diode (SOLED)
- (5) Inverted Organic Light Emitting Diode (IOLED)

## 5. Describe the construction and working of a semiconductor laser (homojunction) with necessary diagrams. Also compute its advantages, disadvantages and applications?

### Principle

*When a  $p - n$  junction diode is forward biased the electrons from  $n -$  region and the holes from  $p -$  region cross the junction and recombine with each other. During the recombination process the photons (light radiation) is released from direct band gap semiconductor (Eg: GaAs) which stimulates other electrons and holes to recombine and hence the stimulated emission takes place which produces the laser*

### Construction

The basic construction of a semiconductor homojunction diode is shown in the figure

#### *Laser output*

The active medium is a  $p - n$  junction diode made from a single crystal of GaAs. This crystal is cut in the form a platelet of thickness 0. 5mm.this platelet has an electrical ( $n$ -type) and hole conductivities ( $p$ -type)

The photon emission is stimulated by a thin layer of PN junction. The potential difference is applied to the homojunction diode through the metal contact. the end faces of the junction are polished and made parallel to each other. They act as optical resonator (the diode has high refractive index) where the laser comes out.

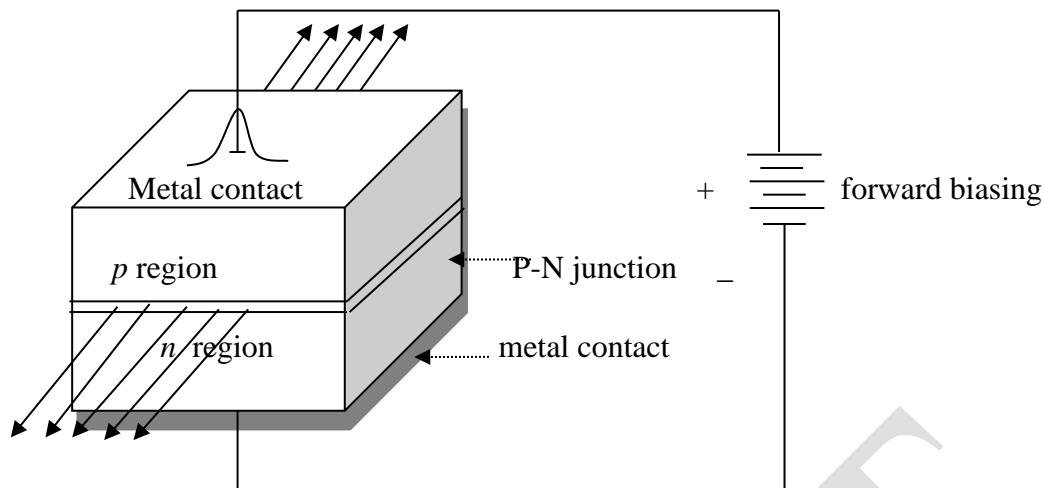

**Working**

Figure shows the energy level diagram. When the diode is forward biased using the applied potential difference, the electron and holes are injected in to the junction where the concentration of holes in *p* – region and electrons in *n* - region strengthens. After the population inversion condition is achieved, the electrons and holes are recombined to produce a radiation in the form of light

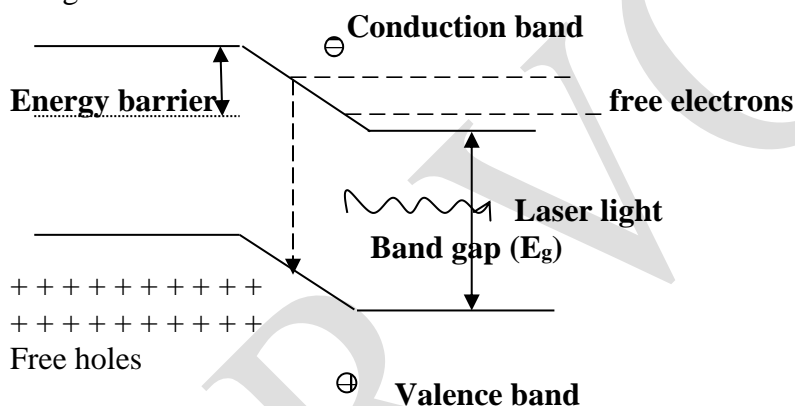

When the forward biased voltage is increases, the emitted photon multiplies and triggers these recombining photons in phase. These photons moving at the plane of junction travels back and forth by reflection between two sides of the junction and grows in strength. After gaining enough strength it emits a laser beam of wavelength  $8400\text{\AA}$ . The wavelength of emitted radiation depends on (i) band gap & (ii) the concentration of donor & acceptor atoms. The wavelength of laser light is given by  $E_g = h\nu$  (or)  $\lambda = \frac{hc}{E_g}$  where  $E_g$  – band gap energy &  $\nu = c / \lambda$

**Characteristics**

01.	Type	Solid state homojunction semiconductor laser
02.	Active Medium	PN junction GaAs diode
03.	Pumping Method	Direct conversion method
04.	Power output	1mW
05.	Nature of Output	Continuous (or) Pulsed
06.	Wavelength	$8400 \text{\AA}$

**Advantages**

- (v) It is small in dimension and compact



- (vi) It exhibits high efficiency
- (vii) The laser output can be increased easily by controlling junction current
- (viii) It requires little auxiliary equipment

**Disadvantages**

- (v) It is difficult to control mode pattern and structure of laser
- (vi) Output beam has large divergence
- (vii) Monochromacity is poorer than other type of laser
- (viii) Threshold current density is large

**Applications**

- (iii) It is used in optical communication
- (iv) It is used to heal the wounds by infrared radiation
- (v) It is used in CD writing and reading

**6. Write a note of quantum well and Quantum size effects**

**7. Explain the electro absorption modulator and SEED as optical switching device.**